



FFI-rapport 2013/01501

Analysis of the Stuhmiller blast injury model



Jan Arild Teland and Stian Sкриudalen



Analysis of the Stuhmiller blast injury model

Jan Arild Teland and Stian Sksiudalen

Norwegian Defence Research Establishment (FFI)

4 June 2013

FFI-rapport 2013/01501

1193

P: ISBN 978-82-464-2252-7

E: ISBN 978-82-464-2253-4

Keywords

Sjokkbølge

Skademodell

Axelsson-modellen

Bowen-kurvene

Stuhmiller-modellen

Approved by

Eirik Svinsås

Project Manager

Jan Ivar Botnan

Director

English summary

The Stuhmiller model for blast wave injury has been studied. Although it has not been documented well in literature, we were able to program the model in Matlab and study some of its properties. It turned out that the Stuhmiller and Axelsson models had been calibrated to more or less the same data. As a result it was possible to derive a relationship between their respective injury parameters.

Further, it was noted that two new injury models could easily be derived, using either the calculated chest wall velocity from Stuhmiller or calculating the irreversible work using the Axelsson chest wall velocities. In particular the Modified Stuhmiller model gave better agreement than any other model when applied to the Johnson data.

Finally, all four injury models were compared with the Bowen curves. Here the original Axelsson model and the Modified Stuhmiller model were in best agreement, which could indicate that chest wall velocity is a better injury parameter than the irreversible work.

Sammendrag

Stuhmiller-modellen for skade på mennesker fra sjokkbølger er blitt undersøkt. Selv om den ikke er spesielt godt dokumentert i litteraturen, klarte vi å programmere modellen i Matlab og studere en del av dens egenskaper. Det viste seg at Stuhmiller og Axelsson modellene hadde blitt kalibrert til omtrent samme data. Dermed var det mulig å utlede en sammenheng mellom skadeparameterene deres.

Videre så vi at to nye skademodeller enkelt kunne utledes, enten ved å bruke den beregnede brystvegghastigheten fra Stuhmiller-modellen eller ved å beregne irreversibelt arbeid ved bruke av brystvegghastighetene fra Axelsson-modellen. Spesielt den modifiserte Stuhmiller-modellen viste seg å være bedre i overensstemmelse med kalibreringsdataene enn noen annen modell.

Til slutt ble alle fire skademodellen sammenlignet med Bowenkurvene. Her viste den originale Axelsson-modellen og den modifiserte Stuhmiller-modellen seg å være i best overensstemmelse, noe som muligens kan indikere at brystvegghastighet er en bedre skadeparameter enn irreversibelt arbeid.

Contents

1	Introduction	7
2	Stuhmiller injury model	7
2.1	Original Stuhmiller model	8
2.2	Trouble with the original Stuhmiller model	9
2.3	Stuhmiller calibration data	9
3	"Evolved" Stuhmiller model	10
3.1	The modified Lobdell model and chest wall velocity	10
3.2	Normalized work	13
3.3	Probability of injury	14
4	Properties of the Stuhmiller model	16
4.1	ASII vs lung injury	16
4.2	Difference between human and sheep	19
4.3	Injury as a function of orientation towards the blast	20
4.4	Relationship with the Axelsson model	23
4.5	Comparison between Stuhmiller and Axelsson	25
5	Possible new injury models	26
6	Comparison between Bowen, Axelsson and Stuhmiller	28
7	Conclusions	31
	References	32
	Appendix A Curve fit parameters	33
	Appendix B Orientation of BTD and the modified Lobdell model	34
B.1	Man	34
B.2	Sheep	35
	Appendix C INJURY 8.3 and in-house Matlab-routine	36
C.1	Software: INJURY 8.3	36
C.2	In-house Matlab routine	37

1 Introduction

In (1) a review of models for predicting blast wave injury to humans was performed. The study in particular looked at the Axelsson model (2) and the Bowen (3) and Bass (4) injury curves. Basically, the conclusion was that the Axelsson BT^D¹ model (and consequently the derived SP² models) seemed to give good predictions.

However, the blast injury model developed by Stuhmiller et al. (5) was not studied in the previous work. This was due to the model not being public and therefore difficult to analyse. After publication of (1), some further information about the Stuhmiller model has been obtained, allowing us to examine it in more detail and compare with the other injury models. The results from this study are described in this report. It is assumed that the reader is already familiar with the material in (1), so no detailed explanation about the Axelsson model, Weathervane model, Bowen curves, BT^D vs SP etc. will be given here.

2 Stuhmiller injury model

The original Stuhmiller BT^D model (5) was published in 1996. This model has several properties in common with the Axelsson BT^D model:

- It is a Single Degree of Freedom (SDOF) model describing the motion of the chest wall.
- The model requires pressure history data from four gauges on a BT^D as input data and uses this input to calculate four chest wall velocities.
- The four chest wall equations are independent.
- The calculated chest wall velocities as a function of time are used to construct an injury criterion.

However, the Stuhmiller model differs from the Axelsson model in two ways:

- The differential equations used to calculate the chest wall velocities are different.
- Instead of Axelsson's maximum chest wall velocity, a different injury criterion based on the irreversible work performed on straining the lung tissue through chest wall motion is used.

Let us look a little more in detail at the Stuhmiller model.

¹ Blast Test Device

² Single Point

2.1 Original Stuhmiller model

In (5) the Stuhmiller equation for the chest wall velocities is given by:

$$m \frac{dv_i}{dt} = p_i(t) - p_0 \left(1 + \frac{1}{2}(\gamma-1) \frac{v_i}{c_0} \right)^{\frac{2\gamma}{\gamma-1}} - \frac{p_0 L}{L-x_i}, \quad (2.1)$$

where $L=V/A$ is the ratio of lung volume to chest wall area and $c_0 = \sqrt{\gamma \frac{p_0}{\rho_0}}$.

After having solved the Stuhmiller equations with the relevant BTD pressure history input, four quantities W_i^* called normalized work can be computed as follows:

$$W_i^* = \frac{W_i}{p_0 V} = \frac{\rho_0 c_0}{p_0 L} \int_0^{\infty} v_i^2 dt \quad (2.2)$$

Finally, the total normalized work W^* can be calculated:

$$W^* = \sum_{i=1}^4 W_i^* \quad (2.3)$$

If BTD pressure data is not available, but only side-on pressure from a single sensor is, Stuhmiller suggested a method similar to the Weathervane model (6), described in Figure 2 of his paper, to estimate the pressure histories.

Stuhmiller suggested that the total normalized work W^* was correlated with the degree of human injury. To find the exact correlation, the Stuhmiller model was calibrated against injury data. Unfortunately, the original Stuhmiller paper is not very explicit about where this calibration data comes from. The only information given is a claim that it is based on experiments against sheep on “the Albuquerque test site”. Apparently, more than 1000 animal tests were recorded in their database from a variety of tests, including “free field exposure to explosions in rooms and vehicles and simulations of weapon fire”. However, sadly, no exact references to these test data are given, although Figure 4 in the paper indicates that the free field studies are from 1981-1991 and the complex wave studies from 1990-1991.

Stuhmiller also created curves for probability of injury as a function of normalized work (see Figure 3 in his paper). However, no underlying theory or mathematical formulas were presented, except it was mentioned that for large animals, $W^*=2.08$ apparently corresponds to 50% lethality.

2.2 Trouble with the original Stuhmiller model

On trying to actually use the original Stuhmiller model, one immediately runs into serious problems. In the original paper it is claimed that linearization of Equation (2.1) for small displacements and velocities will give:

$$m \frac{dv}{dt} = p(t) - \rho c_0 v - p_0 \frac{x}{L} \quad (2.4)$$

But, an inspection of these equations shows that this is not correct. Instead, the linearization should be:

$$m \frac{dv}{dt} = p(t) - p_0 \left(2 + \gamma \frac{v}{c_0} + \frac{x}{L} \right) \quad (2.5)$$

This cast some doubt about how to implement the model. It was not possible to figure out if the linearization of Equation (2.4) was wrong and Equation (2.1) was right, whether Equation (2.4) was correct and there was an error in Equation (2.1), or, if both equations were wrong. Stuhmiller was contacted about this (7) and responded that there was indeed an error in the paper, but, in any case, the whole model had “evolved significantly” since publication. Unfortunately, the new model was not public. However, it was implemented in the INJURY computer program.

2.3 Stuhmiller calibration data

In an article (8) in 1997, Stuhmiller appeared to shed some light on the experimental data used for calibration of the original model. While not explicitly talking about his injury model, Stuhmiller wrote that “*Over the past 15 years, tests have been conducted at the Albuquerque Overpressure Test Site [...] exposing animals to blast loading (Richmond et. al. 1982, Dodd et. al. 1985, Yelverton et. al 1993a,b). Configurations included explosives detonated in the open and in enclosures and simulations of weapons fired from enclosures*”. The phrasing of the sentence is very similar to the description of the calibration experiments in the original Stuhmiller paper, leading us to believe that the three given references are probably the experiments used for calibrating the model.

Closer inspection reveals the 1993 Yelverton reference³ to be the experimental data against which also the Axelsson injury model was calibrated (9). However, in addition the Stuhmiller model

³ Strangely, the 1993 references mentioned by Stuhmiller are wrongly attributed to Yelverton. The actual lead author for these reports is Johnson, with Yelverton being second author. (It must be the same report because the title and contract number are the same. Figure 1 in Stuhmiller’s 1997 paper also refers to Configuration A8, which is the same as described in the Johnson report.) Interestingly, Axelsson also wrongly attributed this experimental report to Yelverton in the paper on his injury model. It is possible that the order of the authors was changed at a late stage, though the Stuhmiller paper is written four years after the Johnson experimental report was published.

seems to be calibrated to data from Richmond (1982) and Dodd (1985). Both these studies deal with exposure to repeated blast waves at relatively low amplitudes. For cases of only one exposure, it therefore looks like the Stuhmiller and Axelsson models are calibrated to exactly the same data! Thus, we should not be surprised if both these models turn out to give roughly similar results.

3 "Evolved" Stuhmiller model

In a paper (10) published in 2012 some more information about the "evolved" Stuhmiller model is given. It turns out that in the newest version of the Stuhmiller model, the original piston-model to calculate the chest wall velocity (whatever the correct equation actually was) had been abandoned and replaced with a modified Lobdell model.

3.1 The modified Lobdell model and chest wall velocity

The original Lobdell model (11) was not developed for human exposure to blast waves, but to assess the human thoracic response from blunt impact. In this formulation, the resultant force acting on the chest wall was due to deceleration of an impacting object with mass m_1 .

In the modified Lobdell model, adapted for blast wave exposure, the impacting mass m_1 is obviously no longer needed. The chest wall (m_2) and thorax (m_3) are set in motion by the force from the impacting pressure wave, interacting with the chest wall and thorax through their effective surfaces A_{eff} and A_b respectively.

The human chest wall is divided into three parts: anterior, left and right hand side. Let's write these chest wall velocities as $v_A(t)$, $v_L(t)$ and $v_R(t)$.

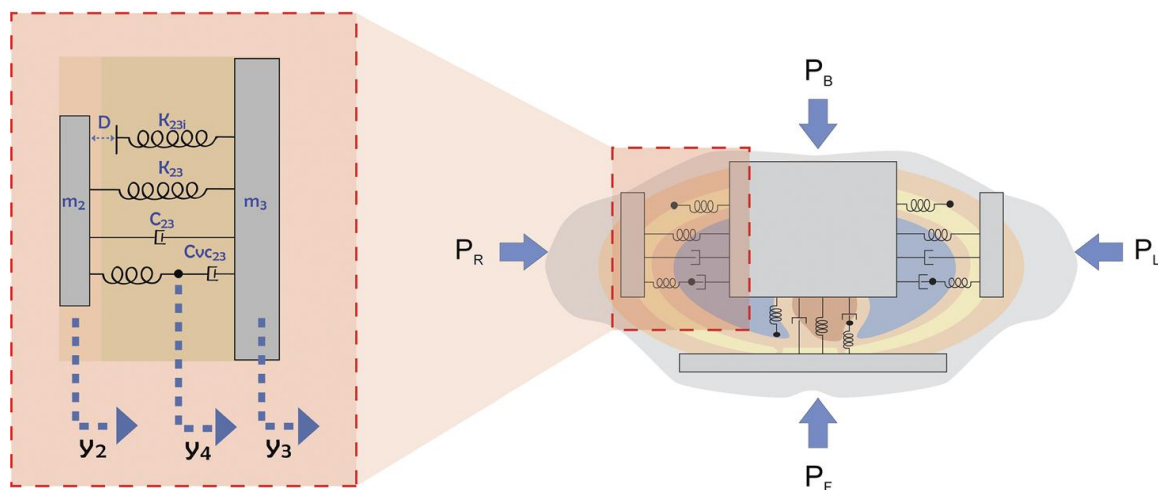

Figure 3.1 Modified Lobdell model used when calculating the chest wall velocity (CWV)

First, it is assumed that the wall stiffness of the left and right sides is similar to that of the anterior; hence identical models could be used to calculate the chest wall velocity for the three

sides. Second, because of the stiff nature of spine with ribs and back muscles, the "chest wall" of the posterior thorax is assumed to have negligible effect on the compression. Hence the entire thorax is modelled using only three moving chest walls (see Figure 3.1).

Their motion is, nevertheless coupled at the centre of mass of thorax (m_3). However, due to the large inertia of m_3 compared to m_2 , the calculations can be simplified or decoupled. This means that when calculating e.g. the chest wall velocity of right hand side we can neglect the chest wall motion on the left side. The pressure on the left hand side is thus assumed impinging directly on the thorax (m_3).

The chest wall velocity is defined as (for a while we skip the subscript indicating which of the tree sides we are looking at since the equations will be identical):

$$v(t) = \dot{y}_2(t) - \dot{y}_3(t), \quad (3.1)$$

and is found by solving the following equations of motion:

$$\begin{aligned} m_2 \ddot{y}_2(t) &= P_2(t) A_{eff} - k_{23} [y_2(t) - y_3(t)] - c_{23} [\dot{y}_2(t) - \dot{y}_3(t)] .. \\ &\dots - k_{ve23} [y_2(t) - y_4(t)] - k_{eff} [y_2(t) - d - y_3(t)] \end{aligned} \quad (3.2)$$

$$\begin{aligned} m_3 \ddot{y}_3(t) &= P_2(t) (A_b - A_{eff}) - P_3(t) A_b + k_{23} [y_2(t) - y_3(t)] + c_{23} [\dot{y}_2(t) - \dot{y}_3(t)] .. \\ &\dots + k_{ve23} [y_2(t) - y_4(t)] - k_{eff} [y_2(t) - d - y_3(t)] \end{aligned} \quad (3.3)$$

$$k_{ve23} [y_2(t) - y_4(t)] = c_{ve23} [\dot{y}_4(t) - \dot{y}_3(t)] \quad (3.4)$$

We have used the notation:

$$\ddot{y}_i(t) = \frac{d}{dt} \dot{y}_i(t) = \frac{d}{dt} \left(\frac{dy_i(t)}{dt} \right), \quad i \in [2, 3, 4] \quad (3.5)$$

Now, y_2 , y_3 and y_4 are the displacements of the two masses and the intermediate point as seen in Figure 3.1. A_{eff} is the effective area of the chest wall, while A_b is the whole body (thorax) area. The k 's and c 's are spring stiffness and damping coefficients. These parameters are given in Table 3.1 for a 50th percentile male with mass 75 kg (average human mass).

For subjects with a mass m_t , which differs from the average human mass, the constants are scaled according to the rule given in the same table. R is the ratio of the two masses:

$$R = \frac{m_t}{m_h} \quad (3.6)$$

Table 3.1 Constants used to calculate chest wall velocity, their nominal value (50th percentile human male with mass 75 kg), and the applicable scaling rules.

Constant	Description	Nominal value	Scaling rule
m_2	Mass of chest wall	0.45 kg	$\times R$
m_3	Mass of thorax (whole body)	27.20 kg	$\times R^{1/3}$
k_{23}	Spring constant (chest wall to whole body)	26300 N/m	$\times R^{1/3}$
k_{23i}	Spring constant, effective at $(y_2 - y_3 = d)$	52600 N/m	$\times R^{1/3}$
k_{ve23}	Constant for spring in series with damper	13200 N/m	$\times R^{1/3}$
c_{23c}	Damping factor in compression, effective when $\dot{y}_2 - \dot{y}_3 > 0$	520.0 N s/m	$\times R^{2/3}$
c_{23e}	Damping factor in expansion, effective when $\dot{y}_2 - \dot{y}_3 < 0$	1230 N s/m	$\times R^{2/3}$
c_{ve23}	Constant for damper in series with spring	180 N s/m	$\times R^{2/3}$
d	Distance chest must move to activate k_{23i}	0.0381 m	$\times R^{1/3}$
A_b	Total frontal blast area of thorax (whole body)	0.10597 m ²	$\times R^{2/3}$
A_{eff}	Effective area of chest wall in motion	0.01750 m ²	$\times R^{2/3}$

For sheep, the average mass is 42 kg; hence the constants in Table 3.1 are scaled accordingly.

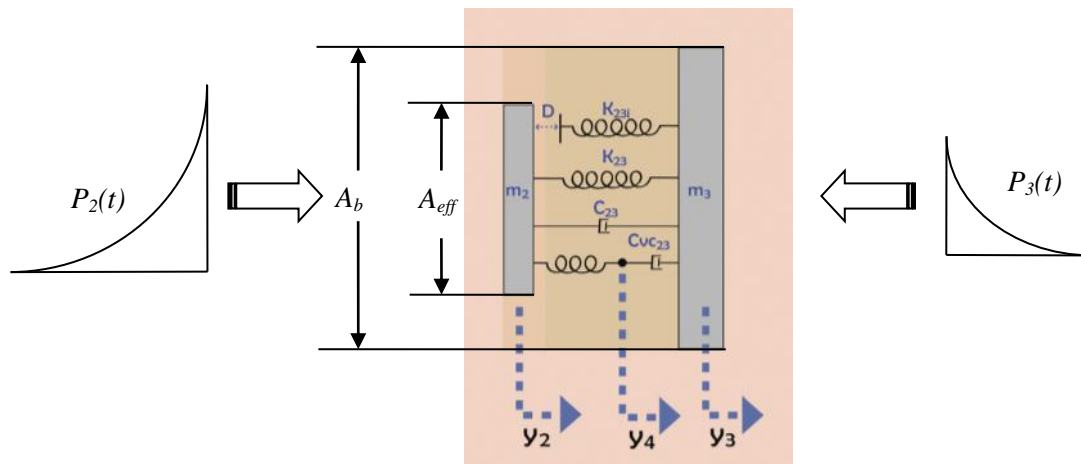

Figure 3.2 Figure showing the input pressure acting on the m_2 side (the movable chest wall) and the m_3 side (whole body or thorax side).

The pressure traces used as input to calculate the chest wall velocities is measured by a blast test device (BTD). For each calculation one needs the two pressure traces, the one impacting the chest wall and its rear counterpart. $P_2(t)$ and $P_3(t)$ is the pressures acting on the m_2 and m_3 side of the modified Lobdell model respectively, as shown in Figure 3.2. The pressure on the m_2 side interacts both with the movable chest wall with an effective area A_{eff} , and the thorax over the area

$(A_b - A_{eff})$. The pressure on the m_3 side (“back side”) interacts with thorax only having the total area A_b .

The outcome of the above calculations are the chest wall velocities for three moving chest walls: Anterior $v_A(t)$, left $v_L(t)$ and right $v_R(t)$. While Axelsson based his injury criterion on the average maximum chest wall velocities, Stuhmiller had a quite different approach.

3.2 Normalized work

Stuhmiller related the injury to a quantity called normalized irreversible work. The irreversible work performed on the lung (normalized by the lung volume and ambient pressure) is a function of the calculated chest wall velocities and is defined as follows:

$$W_s = \frac{A_{eff}}{V_0} \int \left[\left\{ 1 + \frac{1}{2}(\gamma - 1) \left(\frac{\rho c v_s(t)}{\gamma P_A} \right) \right\}^{\frac{2\gamma}{\gamma-1}} - 1 \right] v_s(t) dt \quad (3.7)$$

$s \in [A, L \text{ or } R]$ indicating the three sides anterior (A), left (L) and right (R).

V_0 is the initial lung volume, γ is the ratio of the specific heats, P_A is the ambient pressure and ρ is the lung bulk density. Values are given in Table 3.2.

Table 3.2 Constants used in calculation of normalized work.

Constant	Description	Value	Scaling rule
V_0	Initial lung volume	0.00402 m ³	x R
γ	Ratio of specific heats	1.4	-
ρ	Lung bulk density	100 kg/m ³	-
P_A	Ambient pressure (at standard conditions)	101.325 kPa	-

The sound speed c in lungs is given by (assuming adiabatic conditions):

$$c = \sqrt{\frac{\gamma P_a}{\rho}} \quad (3.8)$$

The total effective work is then defined in the following way:

$$W_{eff} = \left[f_c W_c^2 + f_l W_l^2 + f_r W_r^2 \right]^{0.5} \quad (3.9)$$

f_c, f_l and f_r are fractional surface loading area for anterior, left and right chest wall of the subject. These coefficients are given in Table 3.3 and are different for sheep and human.

Thus, the Stuhmiller model is species dependent, meaning it will give different injury predictions for a (theoretical) sheep and human of the same mass.

Table 3.3 Fractional surface loading area coefficients for sheep and human

	f_c	f_l	f_r
Sheep	0.20	0.40	0.40
Human	0.50	0.25	0.25

3.3 Probability of injury

To correlate the normalized work with injury, the same sheep data as for the original Stuhmiller model was used, possibly with some additional (non-lethal) data points.

However, unlike in development of the Axelsson model, the ASII injury scale was not used in scoring the injury. Instead only the lung component of the ASII was used. More precisely, lung injury was graded based on the observed fractional surface area of contusion in four categories:

- Trace: (<1 %)
- Slight (1-10 %)
- Moderate (10-50 %)
- Severe (> 50 %)

Data were binned into groups "trace or greater", "slight or greater", "moderate or greater" and "severe". For each injury group the probabilistic outcome of injury occurrence, P , was fit to the data by the following equations:

$$P(> level) = \frac{\exp(L)}{1 + \exp(L)}, \quad (3.10)$$

where

$$L = b_0 + b_1 \ln(W_{eff}) + b_2 \ln(ns). \quad (3.11)$$

Using

$$W_{tot} = W_{eff} ns^{b_2/b_1}, \quad (3.12)$$

equation (3.11) can be written:

$$L = b_0 + b_1 \ln(W_{tot}) \quad (3.13)$$

These equations could be slightly simplified by cancelling some of the exp(log) terms, but we have chosen to keep the form given in the original paper (9) to avoid confusion.

The constants b_0 , b_1 are correlation coefficients and listed in Table 3., whereas ns is the number of exposures leading to a “total effective work” W_{tot} . The effect from multiple exposures was established using only the "moderate or greater" injury group, due to a small number of data points available for the others. It was further assumed that this rule was applicable to all injury data groups. So the b_2 value is only given for "moderate or greater". Hence, ns in equation (3.12) should be multiplied by the ratio b_2/b_1 from the “Moderate or greater” group, while b_0 and b_1 parameters in equation (3.13) should be according to the injury group of interest.

Only 15 lethalties were recorded out of 561 samples, using the data set exposed to complex blast waves. These were used to correlate the lethality as function of normalized work. The correlation coefficients are also given in 3.4.

Table 3.4 Parameters defining L in equations (3.11)-(3.13). Reproduced from (10).

	b_0	b_1	b_2
Trace or greater	11.8694	2.2167	
Slight or greater	9.4931	2.0937	
Moderate or greater	7.1169	1.9706	0.5990
Severe	3.8187	1.7938	
Lethality	8.4547	3.3828	

Figure 3.3 shows the probability of injury for the various categories. The occurrence of an injury level is found by taking the difference of the appropriate incidence curves.

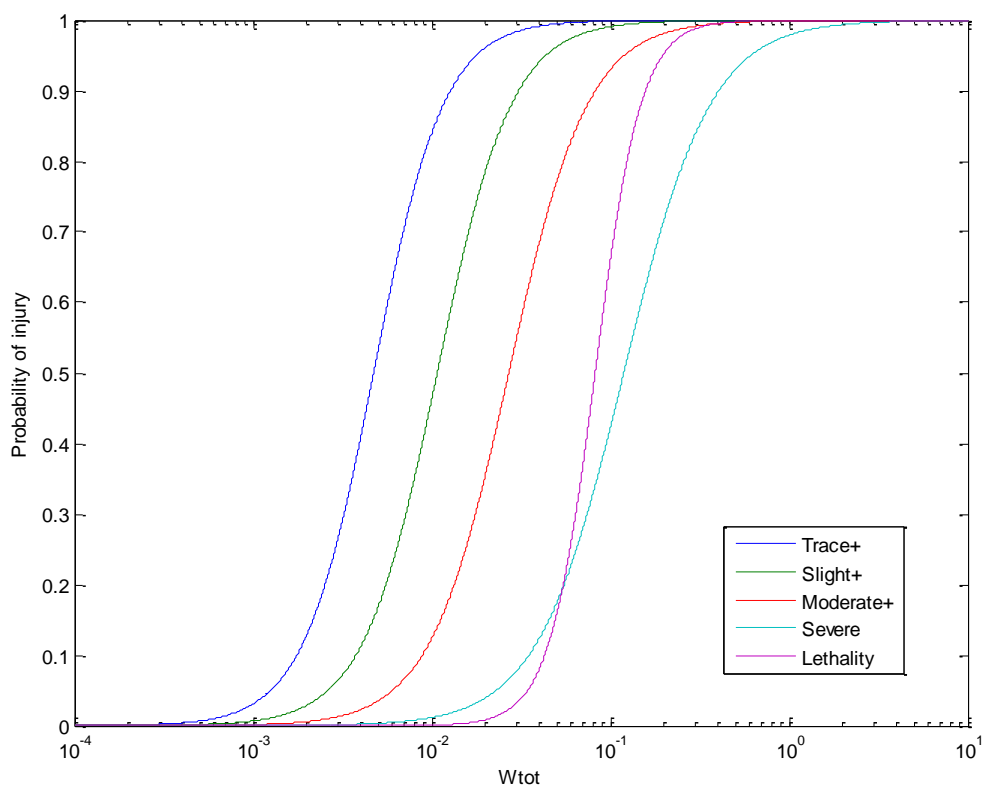

Figure 3.3 Probability of injury for the different categories with $ns=1$.

4 Properties of the Stuhmiller model

Now that all details of the Stuhmiller model are available to us, it can be interesting to study some of its properties, especially how it compares with the slightly similar Axelsson model.

The latest version of Stuhmiller’s injury model is implemented in the computer program INJURY 8.3, which FFI has been able to obtain. Further details about the code are given in Appendix C. However, based on the description in Chapter 3, we have also developed an in-house Matlab program (see Appendix C), which does basically the same thing as INJURY 8.3.

To study the Stuhmiller model, INJURY 8.3 could be used as a “black box”. However, to achieve a proper understanding, the Matlab code is both much more convenient to run and also gives us full control and insight into the internal workings. The Matlab code was therefore used in our exploration of the Stuhmiller model.

4.1 ASII vs lung injury

As noted earlier, both the Axelsson and Stuhmiller model use pressure input from a BTD, but with a different differential equation and different injury criterion. On the other hand, both are calibrated to more or less the same experimental data (as long as we are looking at non-repeated exposure), but in a slightly different way. Let us look at this difference a little more closely.

In the Johnson experiments, sheep inside enclosures were exposed to blast waves. For each test, the corresponding sheep injuries were documented very thoroughly. Each sheep was studied and a numerical value was given for the degree of injury to each of the followings organs:

- Lungs
- Phalynx/Larynx
- Trachea
- GI Tract
- Intra-abdominal

The injury score for each organ was normalised so that the maximum score was 1.0. In addition, points were given according to the extent of pneumothorax, hemoperitoneum (internal bleeding), coronary air or cerebral air. (In practice, it was only the internal bleeding that was sometimes different from zero).

All these scores were then summed to obtain the Adjusted Severity of Injury Index (ASII). (There was also some minor correction for ear injury). Johnson multiplied the ASII score by a factor of 2 if the sheep died, whereas Axelsson did not do this in his analysis. Here we follow the Axelsson convention.

Axelsson used a curve fitting procedure to correlate the maximum chest wall velocity V from his injury model with the measured ASII-score. As explained in Chapter 3.3, Stuhmiller had a different approach and did not use the measured total ASII scores at all. Instead his injury parameter was correlated only with the lung injury component. This can be justified from the assumption that lung injury is most likely to lead to lethality, and as we will see below correlates well with the injury parameter.

So, Axelsson and Stuhmiller had different approaches when dealing with the injury data. It is not clear how the final results are influenced by these two approaches. To gain some further insight, we study the relationship between each component score for an organ and the total ASII. This information is readily available in the Johnson report (9) and is plotted in Figure 4.1.

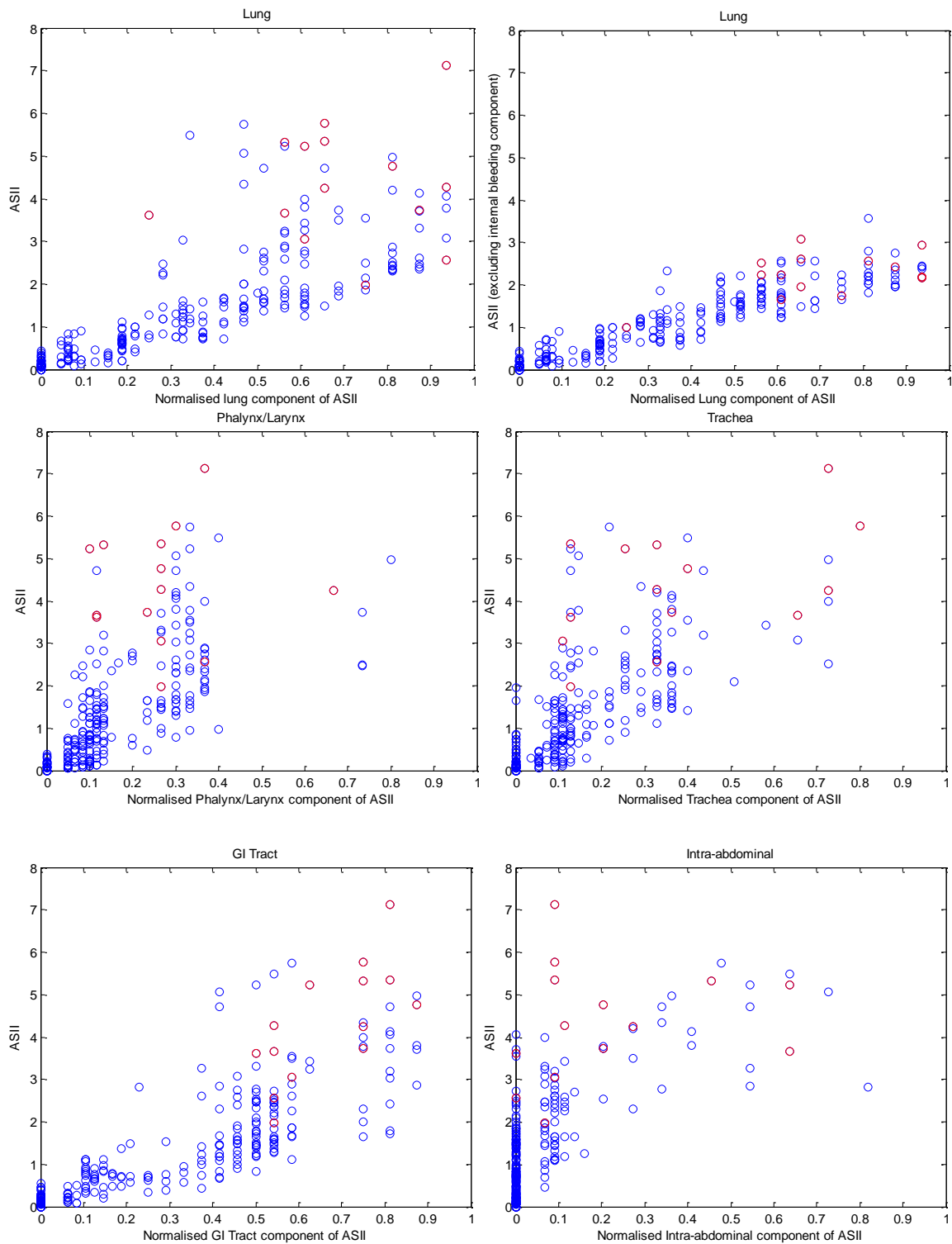

Figure 4.1 Relationship between total ASII and each injury component in the Johnson experiments. (Red denotes a dead sheep).

We see that in particular the lung component and the GI Tract component is closely correlated to the total ASII. Especially between the lung component and the ASII without the internal bleeding component, the correlation is excellent. The relatively good correlation seems to indicate that

lung injury is a good indicator of overall injury. Thus, it should probably not make too much difference that Stuhmiller used only the lung component instead of the ASII.

4.2 Difference between human and sheep

We saw earlier that the Stuhmiller model is slightly different for human and sheep, see Equation (3.9). This means that when exposed to the same blast wave, the injury or lethality for a human and sheep will be different. The Axelsson model does not have this property, where the only parameter describing the subject is the subject mass.

It is not possible to see how big this “species effect” would be in a given situation just from looking at the Stuhmiller equations. The natural way of gaining insight is to examine how the irreversible work W calculated from Equation (3.9) for sheep and human varies as a function of different BTD blast input data.

In principle, we could feed random data in Equation (3.9) and see what happens (for sheep and human), but as a test, we have started with all scenarios in the Johnson experiments, where we already have numerical BTD data available. All except one of these scenarios are in an enclosed container, with the subject exposed relatively close to a wall, so the blast field is relatively complex and should give us a good idea of how the human/sheep assumptions work out in a practical situation.

We emphasize that the idea is not to compare lethality for a given human and sheep, but to investigate the influence of the two sets of fractional surface loading area parameters (f_c , f_l and f_r) used to calculate the total normalized work. Our aim is to get an impression on the importance of these different mathematical assumptions for sheep and human, i.e. whether the difference between calculated normalized work is minor or relatively large, whether it is relatively constant or varies a lot as a function of different input data. Hence, in both cases, a mass of 70 kg was used for the subject (this is the “default” mass value both in the Axelsson and Bowen injury models).

In Figure 4.2 we have plotted the ratio between $W(\text{man})$ and $W(\text{sheep})$ for all the experiments, assuming right hand side facing the blast. Each number along the x-axis belongs to a given experimental configuration in the following order: A1, A2, A3, A4, A5, A6, A8, A8-2, A8-3, A8-4, A8-5, A9, A9-2, A9-3, A10, A10-2, C1, C1-2, C1-4, D1, D1-2, D1-4, Free field (See the Johnson report (9) for details about the different experimental set-ups).

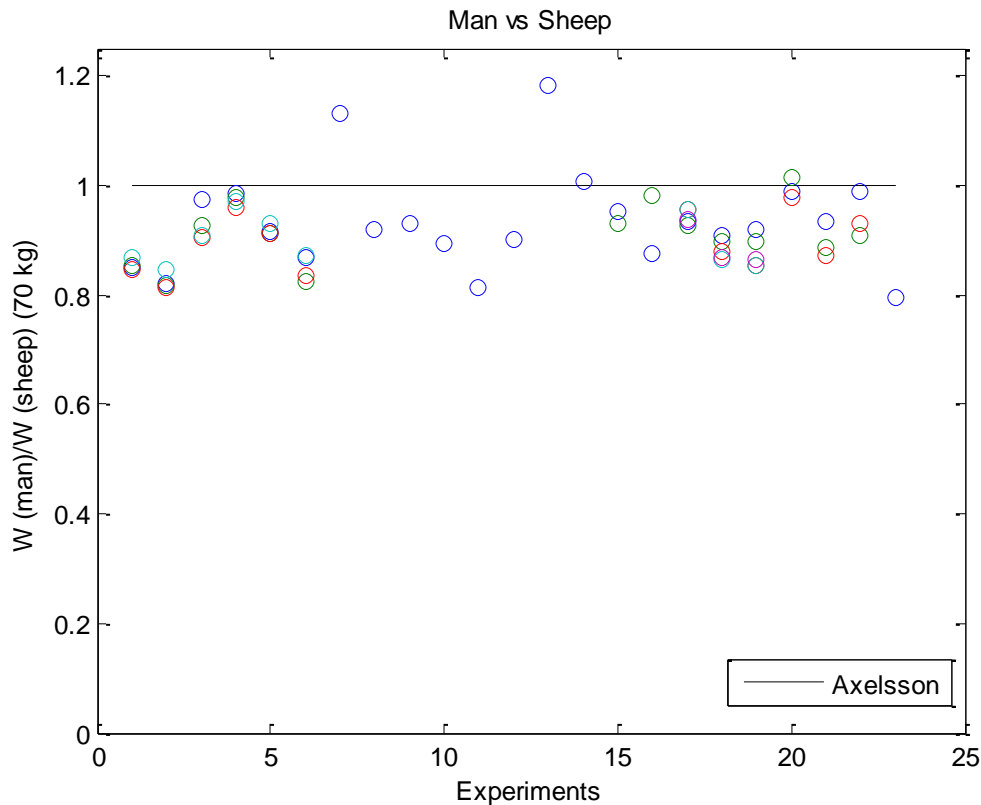

Figure 4.2 Comparison between irreversible work for human and sheep in the various Johnson scenarios.

We see that in most cases, it is slightly more dangerous to be a (hypothetical) sheep than a human of same mass, but the difference is not very big, usually less than 20% normalized work. However, there are two exceptions (A8 and A9-2) in which a human would get more injury than a sheep, so the relationship is quite complex and it is not possible to find a simple rule to estimate the difference between sheep and human.

The Stuhmiller model has tried to account for differences in anatomy between sheep and human and therefore the results differ slightly from the Axelsson model, but clearly the difference is usually small. Obviously, since no experiments have been performed on humans, we have no way of saying whether the Axelsson assumption (no difference) or Stuhmiller assumption (some difference) is correct. As mentioned earlier, in a practical situation, the different mass of human and sheep would obviously also have to be accounted for as well.

4.3 Injury as a function of orientation towards the blast

The Axelsson model is independent of orientation of the sheep. It does not matter if the subject is facing the blast or is right side-on, left side-on or has the back towards the blast. However, the Stuhmiller model is slightly dependent on the orientation of the subject towards the blast source, as explained in Appendix B.

Again, it is not obvious from the Stuhmiller equations how sensitive the model actually is to the orientation relative to the blast. To test this, it is again necessary to feed different BTD data into the model and compare the results.

In a similar way to our investigation of the difference between human and sheep in Chapter 4.2, we will use the blast output from the numerical simulations of the Johnson experiments to do this. Again we are assuming a mass of 70 kg for both species, whereas in practise a human would typically be heavier than a sheep. We emphasize that the idea is just to get an overview of the importance of the Stuhmiller orientation effect in some typical indoor blast situations, not to calculate lethality for a given sheep/human. We want to get a feeling for whether the orientation effect can be large, small, negligible, is almost the same in every blast situation or differs greatly depending on the blast field. Note that in most Johnson experiments, the subject has been exposed relatively close to a reflecting wall.

The results are shown in Figures 4.3-4.5 for both sheep and human. In presenting the results, we have normalised the calculated irreversible work with respect to the right hand side orientation towards the blast source. Thus, if for one particular orientation, this ratio is above 1.00, it means that the right orientation gives lower value for W and is therefore safer than the other orientation.

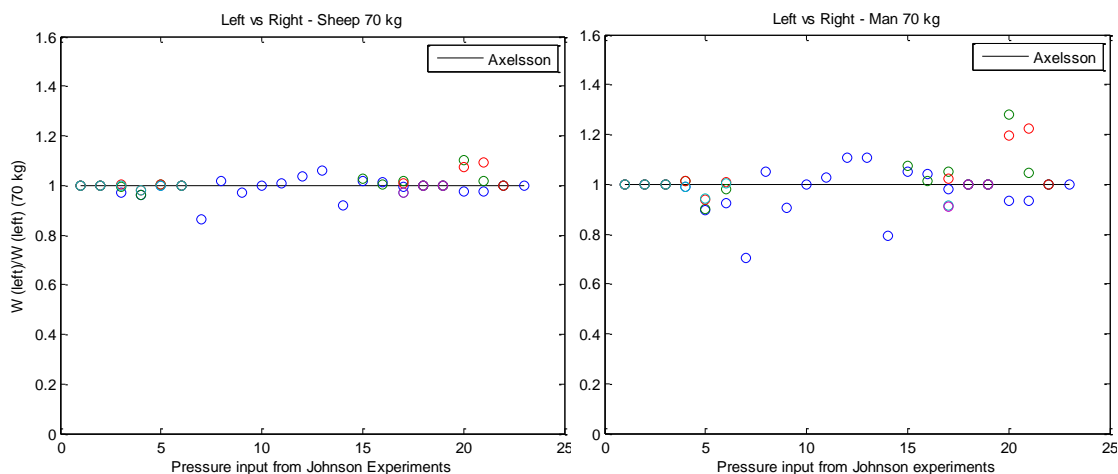

Figure 4.3 Comparison between left and right hand side orientation in the Johnson scenarios.

We see that in most cases it does not matter much whether the sheep is oriented left or right. This seems reasonable. However, for a human the difference is larger and sometimes there is a quite substantial difference between left and right orientation. These are typically scenarios where either of the left or right hand was exposed to higher pressures than the other side. We see that in the symmetric cases (between left and right), like A1-A3 and free field, the ratio is exactly 1.0, which is to be expected.

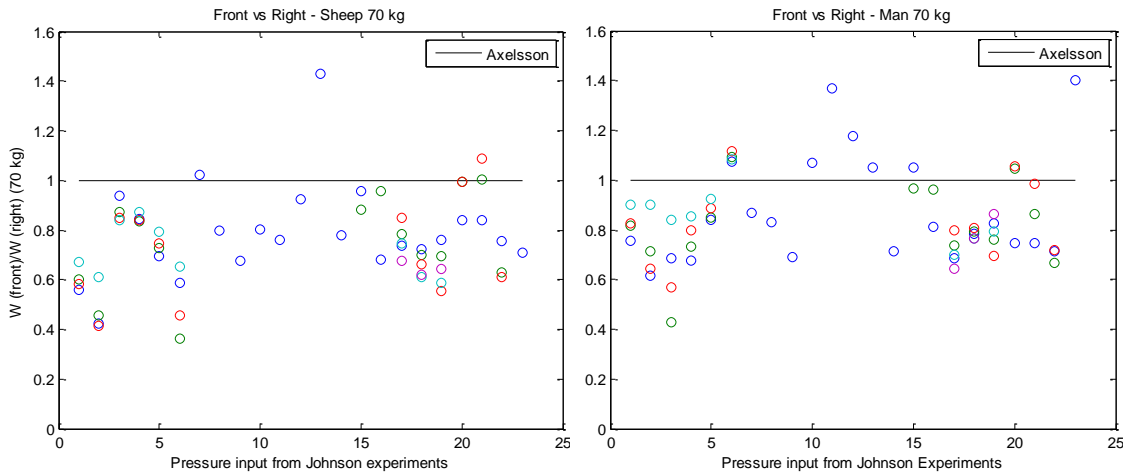

Figure 4.4 Comparison between front and right hand side orientation in the Johnson scenarios.

In most cases, $W(\text{right})$ is larger than $W(\text{front})$ and thus it seems much safer to be facing the blast than being right side-on to the blast. In some cases, the difference can be very large. In particular, for a sheep, in scenario A6 it is much more dangerous to be facing the blast. Note that in A6, for a man it would be the opposite, slightly more dangerous with the right side against the blast than the front side against the blast.

In the free field situation (right data point) the main difference between the sheep and man becomes apparent. When the man is facing the blast source, the highest pressures is on the chest which also has the largest area of the three moving walls (twice as large as left and right side). The smallest pressure will be at the man's back which does not contribute to the total work. If the man's right side is facing the blast, a smaller area will be exposed to the highest pressure while his left side will be exposed to the smallest pressure, and his back (which does not contribute to W) will face the intermediate side-on pressure.

For the sheep, the right and left side has twice the area of the abdomen (chest). Hence, for a sheep it is better to have the abdomen (chest) facing the blast source than the right (or left) side.

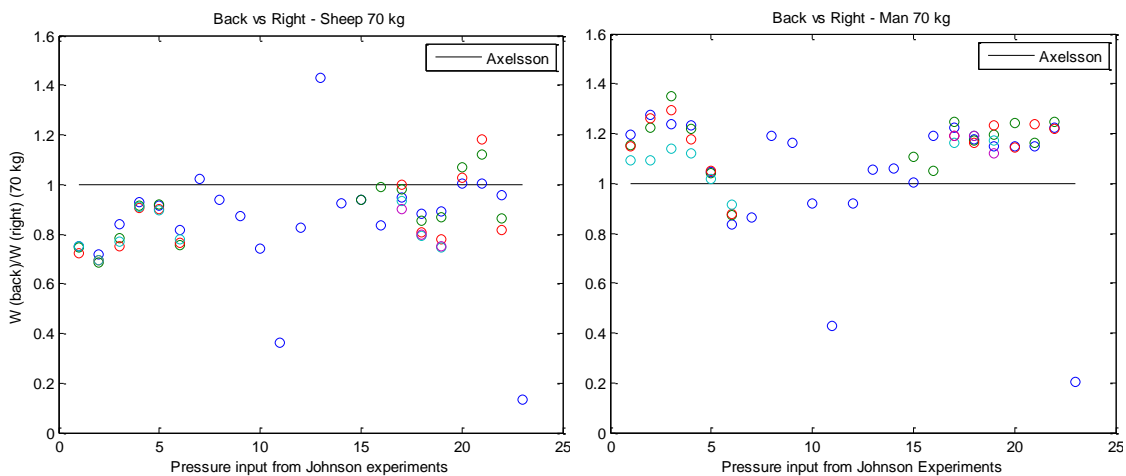

Figure 4.5 Comparison between back and right hand side orientation in the Johnson scenarios.

Finally, in most cases, it is slightly better to have the back facing the blast wave than the right side. However, there are two outliers, A85 and, especially, the free field experiment. In these cases it is enormously much safer to have the back facing the blast, both for sheep and human.

To conclude, we see that in many cases the subject orientation is not that important in the Stuhmiller model either, with differences only being up to 20 %. This is typical for indoor situations with the subject positioned relatively close to a wall, where the blast wave reflects and comes back at the BTM from different directions. In these cases, it would be fair to say that the properties of the Stuhmiller model are similar to the Axelsson model.

However, in some cases the orientation of the subject can be quite important, especially in the free field situation, which is very different from the Axelsson model. The orientation part of the Stuhmiller model is only implemented through the fractional surfaces of the chest walls. No difference is implemented in the modified Lobdell model, which is based on assumptions. There is not much, if any, experimental data available with subject lethality for different orientations, so it is not possible to say whether the Axelsson or Stuhmiller model is correct regarding orientation.

4.4 Relationship with the Axelsson model

The Stuhmiller model calculates the normalised work, from which probabilities of injury and death can be calculated. The Axelsson model only calculates the degree of injury, ASII. In some cases one might be interested in probabilities and sometimes in degree of injury. It is therefore a natural question whether the Stuhmiller model could be extended to calculate the ASII or whether the Axelsson model could be extended to calculate the probability of injury/death.

Such extensions could be easily achieved if there was a relationship between Stuhmiller's injury parameter W and Axelsson's injury parameter V . Such a relationship would not be exact and would also be a function of orientation and species, since, as we have just seen, the Stuhmiller model depends on these variables. However, for one particular orientation and species, let us investigate whether W and V can be related. If so, relation for the other orientations would be trivial to find.

We do this by returning once again to the Johnson experiments (against which both models are calibrated, though in a slightly different manner) and for each experimental configuration (geometry and charge) determine both W and V . When these datapoints are plotted in a diagram, we can easily see how well they are correlated.

This is done in Figure 4.6, for both human and sheep (assuming a mass of 70 kg and with right hand side facing the blast). The "blue points" denote a calculation of W using sheep assumptions and the red points a calculation using "human assumptions" in the Stuhmiller model. Since the Axelsson model is independent of species, only the x-coordinate will be different for sheep and human data points.

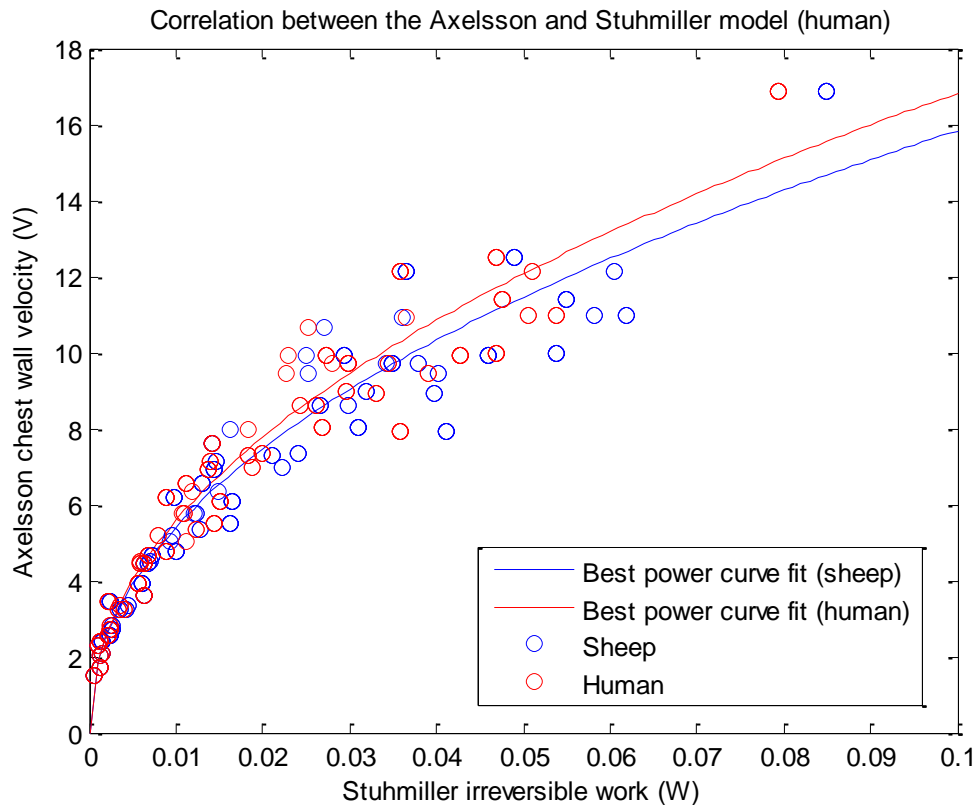

Figure 4.6 Relationship between Stuhmiller and Axelsson injury parameters.

The figure clearly indicates that for a given V , the corresponding Stuhmiller parameter W can be quite accurately estimated. Although there is some scattering of the data, it is not dramatic at all. Using Matlab, a curve fit was attempted on the following form:

$$V = aW^b \tag{4.1}$$

for both human and sheep. The coefficients which gave the best curve fit are shown in Table 4.1 and the corresponding curves have been plotted in Figure 4.6. We note that there is not all that much difference between the human and sheep curve $W(V)$ function, reinforcing our impression from Chapter 4.2.

Table 4.1 Curve fit coefficients for Equation (4.1) for both sheep and human.

	a	b
Sheep	46.38	0.4667
Human	50.62	0.4786

These derived relationships between W and V can now be inserted into Equations (3.10)-(3.13), either to calculate probability of death/injury as a function of V or to calculate $ASII$ as a function of W . This is done in Figure 4.7, which can be compared with Figure 3.4. (Note that for different orientations, the relationships will probably change slightly.)

Further, it is interesting to note that the curve fit for Equation (4.1) gives a relationship where the work W is almost proportional to the velocity V^2 . Such a relationship is what one would have expected from a dimensional analysis.

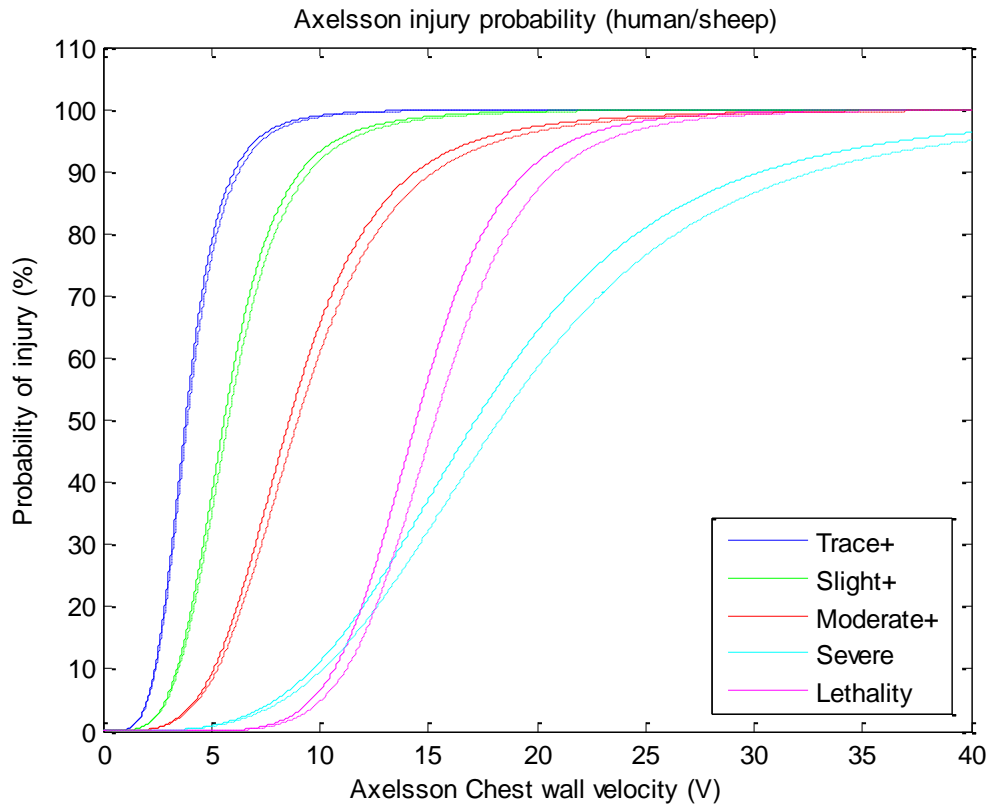

Figure 4.7 Lethality as a function of Axelssons damage parameter V . (Full line = sheep, Dashed line = human)

Note that the lethality curve in Figure 4.7 seems to agree quite well with Axelsson's claim in his original paper (2) that $V=12.8 \text{ m/s}$ should correspond to 50% lethality. Closer inspection gives 50% lethality according to the new curve at $V=14.45 \text{ m/s}$ for sheep and $V=15.30 \text{ m/s}$ for humans, both right side facing blast source.

4.5 Comparison between Stuhmiller and Axelsson

In this chapter we have investigated how much the differences between the Stuhmiller and Axelsson models mean in practise. This has been done by investigating the results that are produced when BTB blast data inside closed containers are used as input. In many cases there was not much difference between the Axelsson and Stuhmiller models. In fact, it seemed quite possible to find correlations between the injury parameters of each model, as we did in Chapter 4.4. This enabled us to extend the Axelsson model to also calculate probabilities of injury and lethality. In Table 4.2 we have summarised the most important properties of the Axelsson and Stuhmiller models. For completeness we have also included the Bowen injury curve.

Table 4.2 Main properties of the Axelsson, Stuhmiller and Bowen injury models.

	Axelsson	Stuhmiller	Bowen
Model parameter	4 chest wall velocities	3 chest wall velocities	None
Model	Four independent differential equations	Three coupled differential equations (in practise almost uncoupled)	None, pure curve fit to experimental data
Injury parameter	Average of the four maximum chest wall velocities	Normalised irreversible work (sum of integral of complicated function of v with a weighing factor)	Maximum amplitude P and duration of positive phase T .
Species dependent	No	Yes, some difference between human and sheep. See Chapter 4.2	No
Orientation dependent	No	Yes, some difference for orientation. See Chapter 4.3.	Yes, different curves for standing and prone.

5 Possible new injury models

We have seen that there is a strong similarity between the Stuhmiller and Axelsson models. Their main difference lies in the differential equation and the injury parameter. However, there is no physical link between the given model and the chosen injury parameter. This means that, in theory, two other “modified” models could now easily be constructed, for example by using the Stuhmiller injury criterion for the Axelsson model and the Axelsson injury criterion for the Stuhmiller model. The two “modified” models are summed up in Table 5.1. Of course, there are other possibilities, but these are very obvious candidates.

Table 5.1 Modified injury models

	Model parameter	Model	Injury parameter
Axelsson (mod)	4 chest wall velocities	Four independent differential equations	Normalised irreversible work (sum of integral of complicated function of v with a weighing factor)
Stuhmiller (mod)	3 chest wall velocities	Three coupled differential equations (in practise almost uncoupled)	Average of the three maximum chest wall velocities

But, would these “modified” models be any better than the original models? One way of finding out is to apply the Johnson blast pressure input data to them and compare their predictions with the measured ASII. If there is less scattering in the data set, the models would be an improvement on the original models, and might be worth examining further. (Note that there will always be some scattering because the same experiment has given different values for ASII.)

Therefore we will compare the scattering for all four models (i.e. original and modified Stuhmiller and Axelsson) when applied to the numerical Johnson data and measured ASII. To calculate the scattering we need to find the best possible curve fit for the ASII as a function of the injury parameter (W or V). It is not physically obvious what form this equation should take, so we will examine two cases that should be quite representative:

- Second degree polynomial $ASII(x) = p_1x^2 + p_2x + p_3$
- Power function $ASII(x) = ax^b + c$

where x will be the injury variable (either V or W depending on model) and the other parameters are constants that will be determined by the best possible curve fit to the data.

In Figure 5.1, the curve fits are shown together with the measured data for all models.

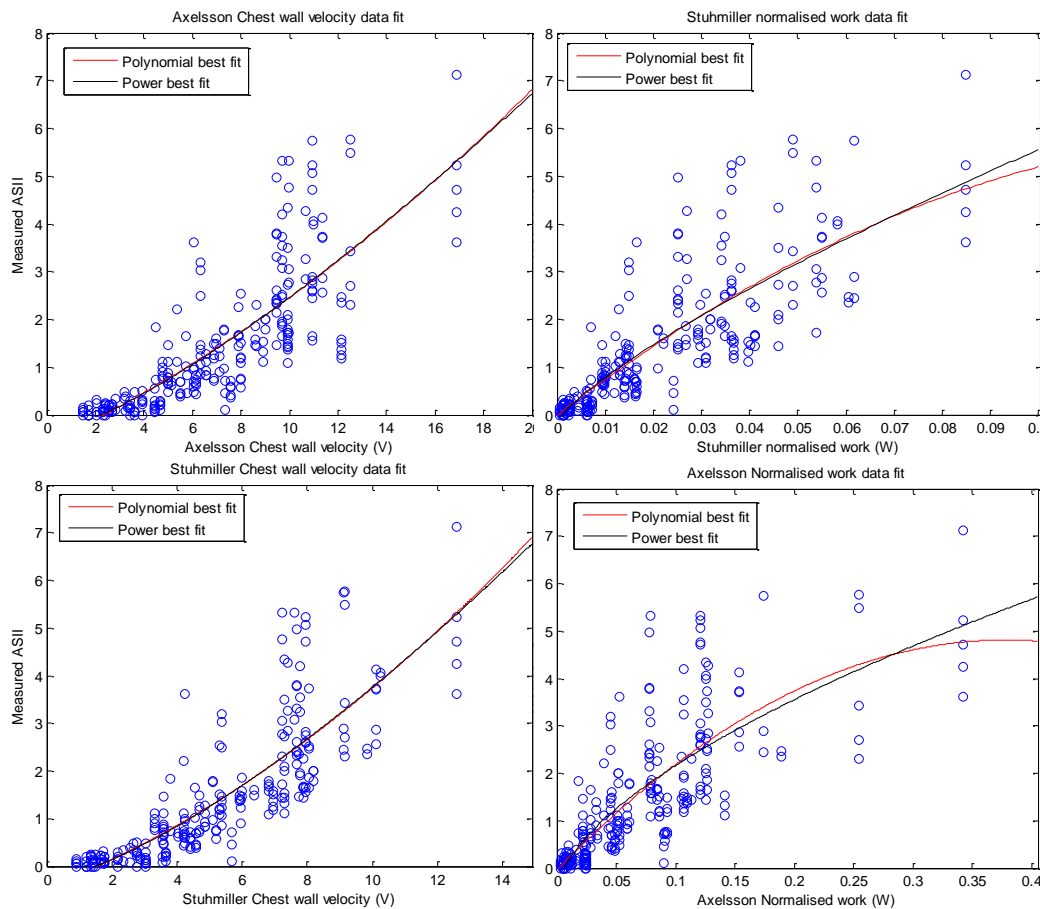

Figure 5.1 Curve fit to data for the different injury models

The actual calculated coefficients are given in the Appendix A. Here we are only interested in the “goodness of fit” statistical parameters. These are Sum Squared Error (SSE), Coefficient of determination (R^2) and Root Mean Square Error (RMSE).

The parameters SSE and RMSE should be as close to zero as possible, whereas R^2 should be as close to 1.0 as possible. All coefficients are shown in Table 5.2.

Table 5.2 “Goodness of fit” parameters to the Johnson data for the four injury models.

2nd order polynomial	V(Axelsson)	W(Axelsson)	W(Stuhmiller - right)	V(Stuhmiller - right)
SSE	181.5	197.1	178.0	160.2
R2	0.6462	0.6158	0.6529	0.6877
RMSE	0.8555	0.8914	0.8473	0.8037

Power function	V(Axelsson)	W(Axelsson)	W(Stuhmiller - right)	V(Stuhmiller - right)
SSE	180.6	198.0	177.6	159.2
R2	0.6479	0.6141	0.6538	0.6897
RMSE	0.8534	0.8934	0.8462	0.8012

We note that the old models V(Axelsson) and W(Stuhmiller) have very similar “goodness of fit” parameters, with W(Stuhmiller) being marginally better (probably not significant). However, the new model V(Stuhmiller) is clearly better than both the old models for both curve fits. In contrast, the new model W(Axelsson) is clearly worse than the old models. This is also very obvious from Figure 5.1. The modified Stuhmiller model might therefore be worth further examination.

6 Comparison between Bowen, Axelsson and Stuhmiller

So, the Axelsson and Stuhmiller models are very consistent when applied to the Johnson data. This is not surprising since both are calibrated to this data. In fact, if they were inconsistent for these data points, at least one of the models would have been seriously miscalibrated.

However, that the models agree for this data set, does not mean that they will always agree. It can be interesting to see how the models compare when applied to data which have not been used in their calibration. One such data set was used to derive the Bowen (3) curves, another injury criterion. The Bowen curves only give probabilities of injury or lethality for a given free field shock wave, for a given subject that is either exposed in an open field or near a wall. To compare the Bowen curves with Stuhmiller and Axelsson, we need to define scenarios which according to the Bowen criterion should give 50 % lethality. A BTM can then be (numerically) exposed to a shock wave from each defined scenario and the measured pressure data can be inserted into the Stuhmiller and Axelsson models to calculate the injury.

Like Axelsson, Bowen does not distinguish between human and animal. The only parameter describing the subject is the mass, with 70 kg being the standard value. We will therefore use this value here in this comparison. For Stuhmiller we will look at both sheep (exposed right side-on) and human (exposed with front chest wall towards the blast).

Such scenarios have already been defined and tested for the Axelsson model in (1). Now the Stuhmiller model (including our modified version) and our modified Axelsson can be applied to these scenarios as well. The scenarios are shown in Table 6.1. We only look at near wall scenarios (which is what Bowen has data for – this is discussed in detail in (1)).

Table 6.1 Scenarios which are investigated

Mass of TNT charge	BTD distance from charge
0.5 kg	1.01 m
1 kg	1.35 m
9 kg	3.40 m
20 kg	4.70 m
200 kg	11.65 m
400 kg	15.10 m
1500 kg	24.50 m

To compare the different injury models, we would like to use the same injury parameter. For the Stuhmiller model we can calculate the 50 % lethality directly from W through Equation (3.10). For the Axelsson model we can use the relationship between V and lethality derived earlier and shown in Figure 4.7.

In the Modified Stuhmiller model, it is slightly more complicated to obtain the lethality, since this has not really been specified yet. One way is to proceed as follows: After finding the chest wall velocity V , we can use the curve fit in Figure 5.1 to calculate a corresponding ASII. From this ASII we use Axelsson’s old ASII(V) equation to find an “artificial” chest wall velocity that would have given the same ASII in the original Axelsson model. And then we use the same method as above for the Axelsson model to derive the corresponding 50 % lethality.

Things have not been quite specified in the Modified Axelsson model either. We proceed in a similar way to our approach with the Modified Stuhmiller model. After the irreversible work W has been derived, we can use the curve fit in Figure 5.1 to find a corresponding ASII value. Then an “artificial” chest wall velocity can be derived according to Axelsson’s old ASII(V) equation. Then the same method as above for the Axelsson model is used to derive the corresponding 50 % lethality.

Using these procedures, we obtain the results which are shown in Figure 6.1.

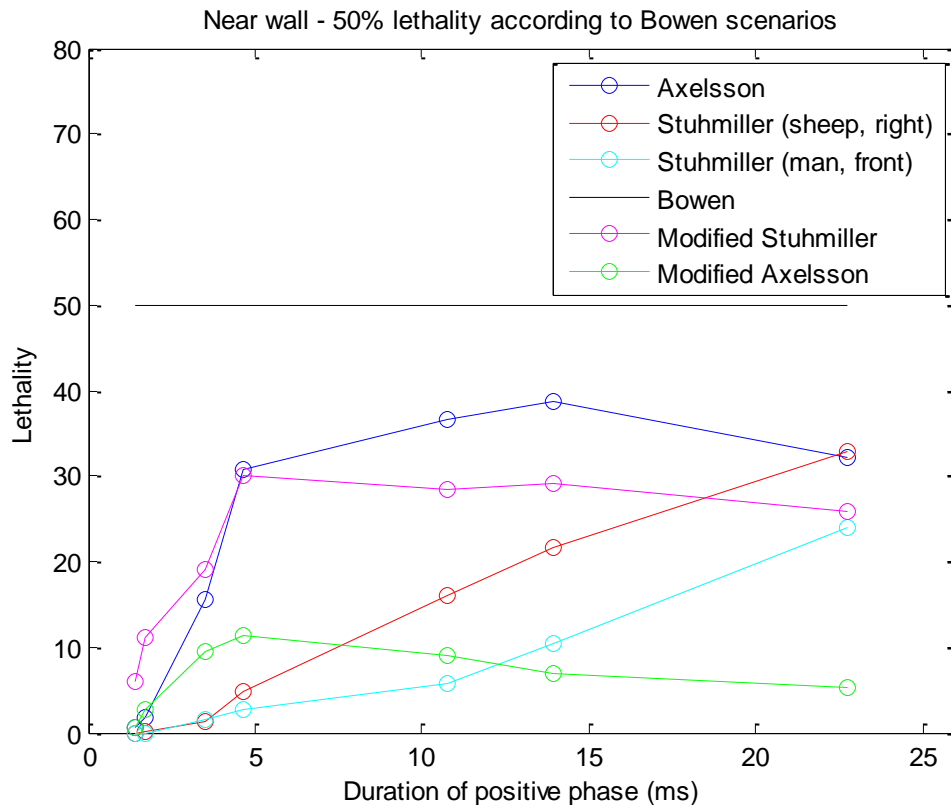

A couple of points are worth noting:

- In all cases the 50 % lethality is underestimated by all formulas compared with Bowen. Especially for short durations the formulas say that the scenarios are much less deadly than Bowen. However, this may be due to errors in the foundation of the Bowen curves, as has been discussed in detail elsewhere (1).
- Since the lethality curve rises very rapidly exactly around the 50 % probability, only small changes in chest wall velocity or work will give a huge difference in lethality. Thus, a prediction of 30-40 % is not much different from 50 %. If the comparison had been expressed in terms of V or W instead of lethality, the correspondence with Bowen would have looked very close (see ref. (1) for this done with the Axelsson model).
- The Modified Axelsson equation is in very poor agreement with Bowen and the other curves. We also saw that this did not fit the experimental Johnson data very well. Thus, this is probably not the way to go.
- The regular Stuhmiller model approaches the Bowen formula for very long durations, but clearly is in worse agreement than Axelsson and Modified Stuhmiller for shorter durations.
- Axelsson usually comes closest to Bowen, but there is not much difference between it and Modified Stuhmiller.
- Modified Stuhmiller is clearly closer to Bowen than all other curves for short durations. It is also the most “stable” curve, giving almost the same lethality for every scenario except the very short ones (where Bowen is likely wrong).

- It would have been possible to calibrate the lethality predictions for the modified Stuhmiller and Axelsson to the Bowen results, instead of using the complicated approach with calculating an “artificial V” from the original Axelsson ASII(V) equation.
- If this was done for the Modified Stuhmiller, we could obtain a model that was in almost total agreement with the lethality predictions of Bowen except for short durations, where Bowen is likely wrong.

7 Conclusions

The Stuhmiller model for blast wave injury due to blast waves has been studied. Although it has not been documented very well in literature, we were able to program the model in Matlab and study some of its properties.

The Stuhmiller model has much in common with the Axelsson model, but has a different set of differential equations to solve and a different injury criterion. It also depends on the orientation of the subject (unlike Axelsson) and differentiates between human and sheep (unlike Axelsson and Bowen).

It turned out that the Stuhmiller and Axelsson models had been calibrated to more or less the same data. As a result it was possible to derive relationship between the irreversible work of Stuhmiller and the chest wall velocity of Axelsson. In this way, ASII could be calculated from the Stuhmiller model and probability of injury and lethality could be calculated from the Axelsson model.

Further, it was noted that two new injury models could easily be derived, using either the calculated chest wall velocity from Stuhmiller or calculating the irreversible work using the Axelsson chest wall velocities. In particular the Modified Stuhmiller model gave better agreement than any other model when applied to the Johnson data.

Finally, all four models were compared with Bowen. Here the original Axelsson model and the Modified Stuhmiller model were in best agreement, which could indicate that chest wall velocity is a better parameter than the irreversible work.

Using these four BTM models, several single point (SP) models can also be derived. However, this topic was seen as beyond the scope of the present study.

From our study, the original Axelsson model and Modified Stuhmiller seems most promising. However, it is too early to conclude with certainty. A possible advantage with the Stuhmiller models is that they depend on whether the subject is human or sheep and on the orientation. This may seem reasonable, but on the other hand, no experiments have actually been performed to verify this. Clearly more research is needed on this important topic. Further work may also look into the single point (SP) procedures applied to the (Modified) Stuhmiller model.

References

- (1) Teland J A, Review of blast injury prediction models, FFI/RAPPORT-2012/00539
- (2) Axelsson H, Yelverton J T, 1996, Chest Wall Velocity Predictor of Nonauditory Blast Injury in a Complex Wave Environment, *The Journal of Trauma: Injury, Infection, and Critical Care*, Vol. 40, No. 3, USA
- (3) Bowen I G, Fletcher E R, Richmond D R, Estimate of Man's Tolerance to the Direct Effects of Air Blast, Technical Progress Report, DASA-2113, Defense Atomic Support Agency, Department of Defense, Washington, DC, October 1968
- (4) Bass C R, Rafaels K A, Salzar R S, Pulmonary injury risk assessment for short-duration blasts, *Journal of Trauma*, Vol. 65, No 3, pp. 604-615, September 2008
- (5) Stuhmiller J H., Ho K H H, VanderVorst MJ, Dodd KT, Fitzpatrick T, Mayorga M, 1996, A model of blast overpressure injury to the lung, *J. Biomechanics*, vol. 29, No. 2, pp. 227-234, 1996, Great Britain
- (6) Li E, Yoshinaka A, Josey T, 2008, Weathervane: a single point model for blast injury approximations, 20th Symposium on Military Aspects of Blast and Shock, 2008, Oslo, Norway
- (7) Stuhmiller J H, Private communication
- (8) Stuhmiller J H, Biological response to blast overpressure: A summary of modelling, *Toxicology* 121 (1997), p. 91-103
- (9) Johnson D L, Yelverton J T, Hicks W, Doyal R, Blast Overpressure Studies with Animals and Man: Biological Response to Complex Blast Waves, Final Report, US Army Medical Research and Development Command, October 1993
- (10) L. N. MacFadden, P. C. Chan, and K. H. Ho, A model for predicting primary blast lung injury, *J Trauma Acute Care Surg.*, vol. 73, no. 5, pp. 1121-1129, 2012
- (11) Lobdell T E, Kroell C K, Schneider D C, Hering W E, Impact response of the human thorax, Proceedings of the Symposium on human impact response, Warren, Michigan, USA, October 2-3, 1972

Appendix A Curve fit parameters

In Table A.1 we present the full curve fit functions to the Johnson data for the various injury models.

- Second degree polynomial: $ASII(x) = p_1x^2 + p_2x + p_3$
- Power function: $ASII(x) = ax^b + c$

Table A.1 Curve fit parameters to Johnson data

	V(Axelsson)	W(Axelsson)	W(Stuhmiller)	V(Stuhmiller)
p₁	0.006491	-33.93	-253	0.01517
p₂	0.2409	25.66	77.35	0.267
p₃	-0.6041	-0.03901	-0.009945	-0.457
a	0.1386	10.76	34.04	0.1622
b	1.316	0.6089	0.7732	1.396
c	-0.4095	-0.4849	-0.1828	-0.2885

Appendix B Orientation of BTD and the modified Lobdell model

The pressure traces used as input to calculate the chest wall velocities is measured by a blast test device (BTD). The four pressure traces from a BTB are $P_F(t)$, $P_L(t)$, $P_R(t)$ and $P_B(t)$; that is the front gauge (which is pointing towards the explosion) and the left, right and back gauge respectively.

Which of these four pressure traces that are used as $P_2(t)$ and $P_3(t)$ in the calculations (see section 3.1), depends on the subject's orientation and which chest wall velocity (anterior, left or right) that are being calculated.

B.1 Man

Standard orientation for man is an upright position with anterior chest wall facing blast source. An overview of how the man's various orientations influence the input to the modified Lobdell model is given in the table below.

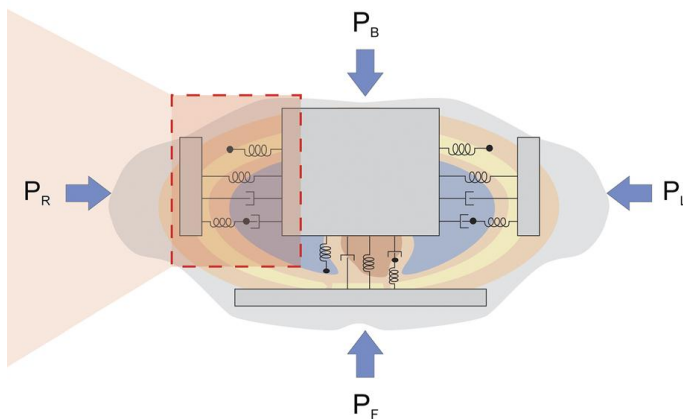

Figure B.1 The Lobdell model compared to the contour of man. Head is pointing out of plane.

Table B.1 Overview of the various orientations for man, and which pressure trace from the BTB to be used as $P_2(t)$ and $P_3(t)$ when calculating the chest wall velocity of the anterior, left and right side of the modified Lobdell model. It is assumed that $P_F(t)$ trace on the BTB is always facing the explosion.

		Chest wall calculation (Modified Lobdell model)					
		Anterior		Left		Right	
		$P_2(t)$	$P_3(t)$	$P_2(t)$	$P_3(t)$	$P_2(t)$	$P_3(t)$
Input traces from BTB	Front side of body facing explosion	$P_F(t)$	$P_B(t)$	$P_L(t)$	$P_R(t)$	$P_R(t)$	$P_L(t)$
	Left side of body facing explosion	$P_R(t)$	$P_L(t)$	$P_F(t)$	$P_B(t)$	$P_B(t)$	$P_F(t)$
	Right side of body facing explosion	$P_L(t)$	$P_R(t)$	$P_B(t)$	$P_F(t)$	$P_F(t)$	$P_B(t)$
	Back side facing explosion	$P_B(t)$	$P_F(t)$	$P_R(t)$	$P_L(t)$	$P_L(t)$	$P_R(t)$

B.2 Sheep

A sheep does not stand on two legs like human being. When a sheep is facing the blast source, that generally means that the head is pointing towards the blast source while all four feet still are on the ground. This would however lead to an orientation where all three moving chest walls and the back of the sheep feel a side-on pressure. However, if the right or left side of the sheep is facing the blast source, the same situations for the pressure loading is found for sheep and man.

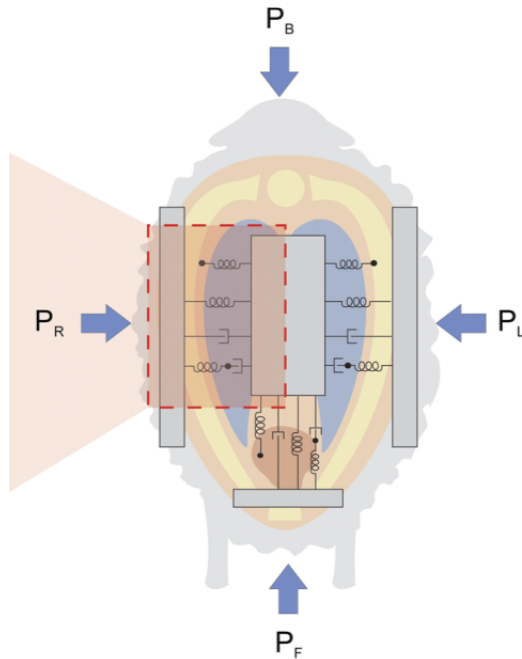

Figure B.2 The Lobdell model compared to the contour of a sheep. Head is pointing out of plane.

For the sheep's orientation, the INJURY 8.3 software is ambiguous compared to Figure B.2. When selecting "Front Side Facing Blast", the red arrow indicating direction of propagation of pressure wave is pointing towards the P_B in the figure above and opposite for "Back Side Facing Blast". Similar we find an interchange for "Left ..." and "Right Side Facing Blast" unless the orientation of the sheep's head in INJURY 8.3 software is pointing into the plane and not out of the plane as in the figure above.

To terminate all confusions we have used the definition found in Figure B.2, which is given in the original paper (11) and which is identical to the definition of man's orientation. Hence, the input scheme given in Table B.1 is valid also for sheep in the in-house Matlab script.

Therefore, if the anterior (or front) chest wall is facing blast, the sheep is found hanging by its neck with all four legs pointing towards the blast source. It is not verified if this is the convention used by the authors, nor is it confirmed that this is the true scheme implemented in INJURY 8.3.

Appendix C INJURY 8.3 and in-house Matlab-routine

This appendix presents the INJURY software developed by USA MRMC, and the in-house matlab program developed at FFI.

C.1 Software: INJURY 8.3



Figure C.1 INJURY 8.3 software.

The latest version of Stuhmiller's injury model is implemented in the computer program INJURY 8.3, which FFI has been able to obtain. The interface of the software is shown in Figure C.1.

The required input is the blast loading, species, body mass, the number of shots, atmospheric pressure and end time. The output of the calculation is the total normalized work, and the probabilities for having a certain injury severity: "none", "trace", "slight", "moderate" and "severe". It also predicts the probability of lethality.

During use, a number of issues and bugs with INJURY 8.3 were identified. Through correspondence with the support team, workarounds were found that enabled the code to be applied.

When using INJURY 8.3, the following is very important:

- Computer settings for region and language must be set to "English" to enable the data files to be loaded. (This is found under "Control panel > Region and Language > Formats" and affects the whole computer).

- Blast input data must be overpressure only. If the blast data includes the ambient pressure, this pressure must be subtracted before loading the data into INJURY 8.3.
- The “stop time” for the blast wave data should not be set to the actual duration of the blast wave, but to a much higher value.
- Before loading the data file into INJURY 8.3, some data points with zero pressure should be added artificially to the end of the data file.
- The orientation of sheep is ambiguous.

C.2 In-house Matlab routine

Through thorough investigation of (11) combined with good support from the authors and support team, the “evolved” Stuhmiller model was implemented as a Matlab routine.

This made it much simpler to run many calculations in batch mode as the input and output formats could be tailored to achieve this.

Model implementation was also more convenient to use for research purposes, since all parameters (especially chest wall velocity) became available, and since we easily could make modifications to the code and see what impact this has on the results.

After programming the Matlab code, the results were compared with INJURY 8.3 showing very good agreement. Thus, the implementation was validated.

Examples of graphical output from the Matlab routine are given in the following figures.

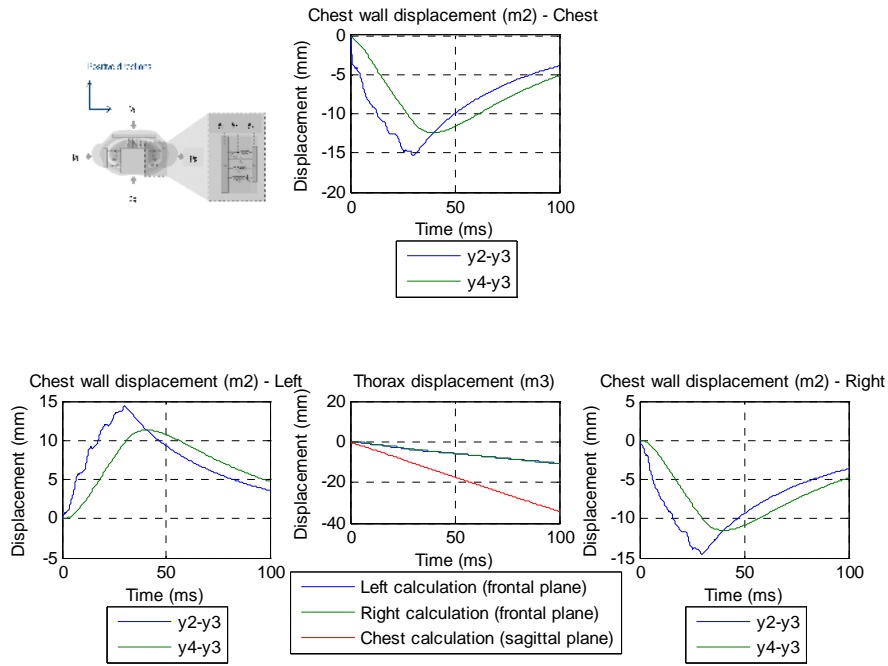

Figure C.2 Plot of chest wall displacement and thorax displacement for all three independent calculations of the chest wall velocity.

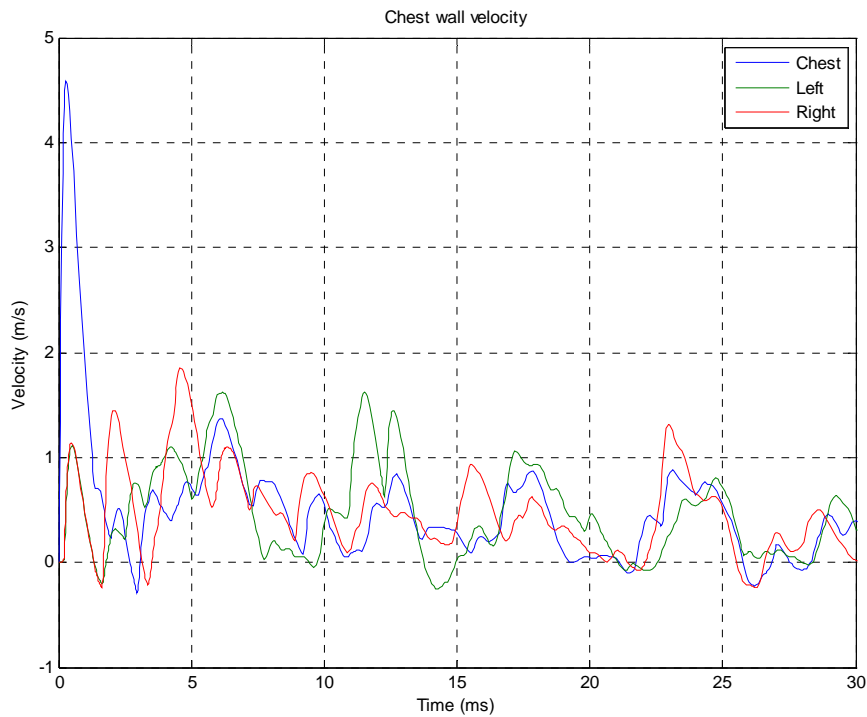

Figure C.3 The chest wall velocity of the anterior (chest), left and right chest wall.

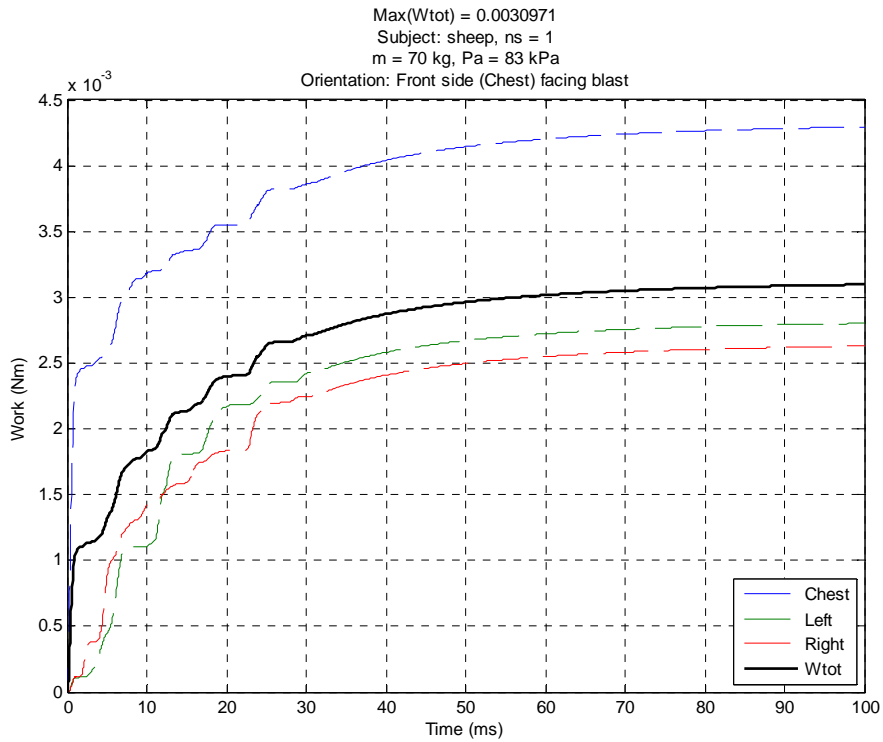

Figure C.4 Calculated irreversible work for the three moving chest wall, and the averaged total irreversible work used to find the probability of injury and lethality.

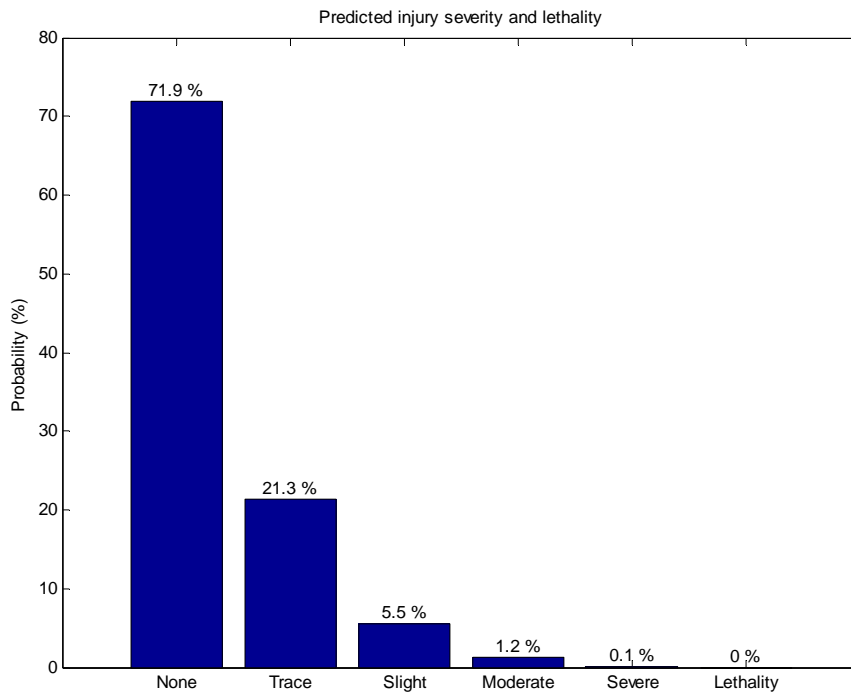

Figure C.5 The probability of injury (for each injury category) and lethality.